

**ENGINEERING MECHANICS**

(Common to ECE, EEE, EIE, Bio-Tech, E Com E, Agri E)

**Time: 3 hours****Max. Marks: 70**

Question Paper Consists of **Part-A** and **Part-B**  
 Answering the question in **Part-A** is Compulsory,  
 Three Questions should be answered from **Part-B**

\*\*\*\*

**PART-A**

- (a) Find the unit vector of the force  $F = 4i - 5j + 8k$ .  
 (b) What is the principle of transmissibility?  
 (c) Use Pappus theorem to find the volume of a sphere of radius  $r$ .  
 (d) State the Parallel axis theorem.  
 (e) State the condition for the dynamic equilibrium of a body under translation.  
 (f) What is instantaneous centre of rotation in plane motion?

[4+3+4+4+3+4]

**PART-B**

- (a) A block weighing 1000 N is kept on a rough plane inclined at  $40^\circ$  to the horizontal. The coefficient of friction between the block and the plane is 0.4. Determine the smallest (least) force inclined at  $15^\circ$  to the plane required just to move the block up the plane.  
 (b) A frame is loaded as shown in Fig. 1. Find the support reactions.

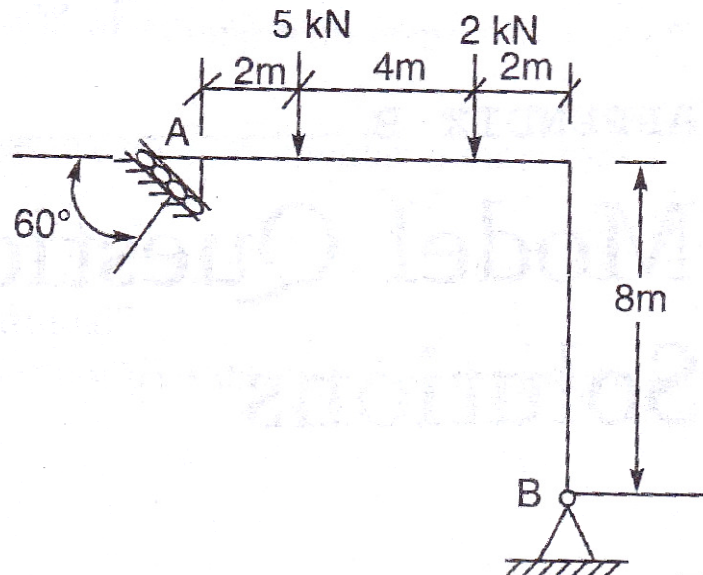

[8+8]

Fig.1



3. (a) Forces 32 kN, 24 kN, 24 kN, and 120 kN, are concurrent at the origin and are respectively directed through the points whose coordinates are A (2,1,6), B(4,-2,-5), C(-3,-2,1), and D(5,1,-2). Determine the resultant.  
 (b) State and prove Varignon's theorem.

[8+8]

4. (a) Calculate the moment of inertia of the section shown in Fig. 2 about its centroidal xx and yy axis.

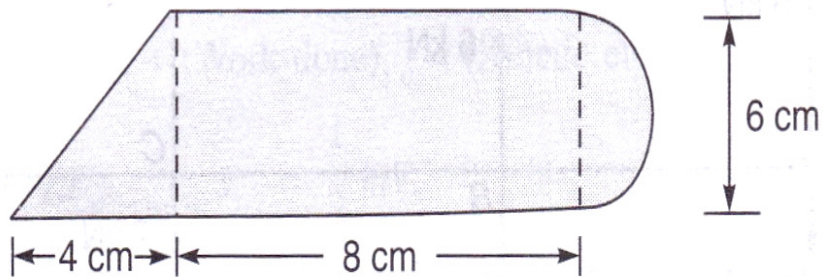

Fig.2

- (b) State and prove perpendicular axis theorem.

[8+8]

5. (a) Find the mass moment of inertia of a thin circular disc ( $I_{xx}$ ,  $I_{yy}$ , and  $I_{zz}$ ).  
 (b) Locate the centroid for the area shown in Fig.3.

[10+6]

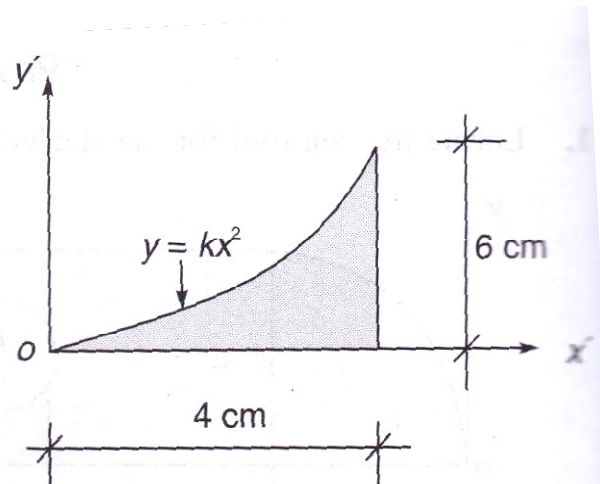

Fig.3



6. (a) Two cars A and B are travelling in adjacent highway lanes. At an instant of time, their positions and speeds are as shown in Fig.4. If car A has constant acceleration of  $0.8 \text{ m/s}^2$  and car B has a constant deceleration of  $0.5 \text{ m/s}^2$ , determine
- (i) When and where car A will overtake car B and
  - (ii) The speed of each car at that time.

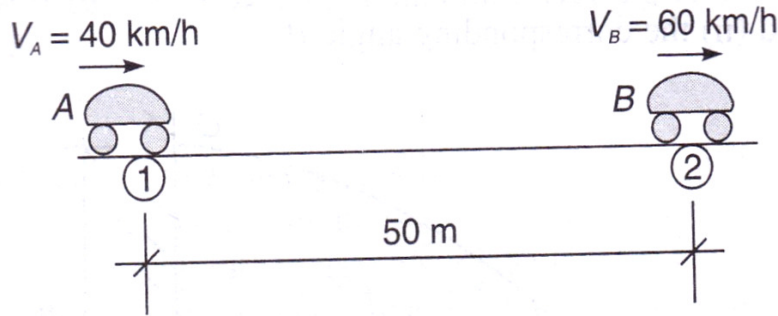

Fig.4

- (b) What is the angle turned by a wheel while it starts from rest and accelerates at a constant rate of  $3 \text{ rad/s}^2$  for an interval of 20 sec. ?

[12+4]

7. (a) Define impulse-momentum principle.  
 (b) Define work energy equation.

[8+8]

\*\*\*\*

