

- 1 An LTI system has the input signal  $x(n)$ . Which of the following sequence of operations is most appropriate to get output  $y(n) = x(n - M/L)$ .
  - a) Interpolation by L, Delay by M, Decimation by L
  - b) Delay by M, Interpolation by L, Decimation by M
  - c) Decimation by L, Delay by M, Interpolation by L
  - d) Interpolation by L, Decimation by L, delay by M
  
- 2 Consider a low pass random process with a white noise power spectral density
 
$$S_X(\omega) = N/2 \quad \text{where } -2\pi B \leq \omega \leq 2\pi B$$

$$0 \quad \text{elsewhere}$$
 The Auto-correlation function  $R_X(\tau)$  is
  - a)  $2NB\text{sinc}(2\pi B\tau)$
  - b)  $\pi NB\text{sinc}(2\pi B\tau)$
  - c)  $NB\text{sinc}(2\pi B\tau)$
  - d) none of the above
  
- 3 Pole-zero plot of a digital filter is shown below, what is the type of filter?

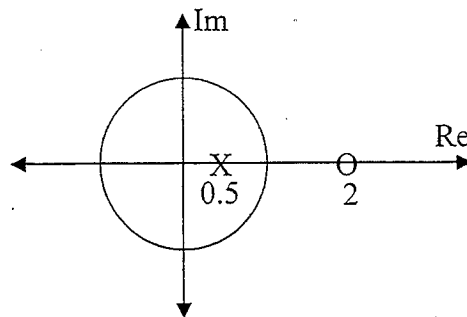

- a) Low Pass                      b) High Pass                      c) Band Stop                      d) All Pass
- 4 Determine the DTFT of the sequence  $y[n] = (n+1)\alpha^n u[n]$ ,  $|\alpha| < 1$ .  $u[n]$  is unit step sequence.
    - a)  $Y(e^{j\omega}) = 1 / (1 - \alpha e^{-j\omega})^2$
    - b)  $Y(e^{j\omega}) = 1 / (1 + \alpha e^{-j\omega})^2$
    - c)  $Y(e^{j\omega}) = \alpha / (1 - \alpha e^{-j\omega})^2$
    - d) none of the above
  
  - 5 The function  $f(t)$  has the Fourier transform  $g(\omega)$ . The Fourier transform of  $g(t)$  is
    - a)  $f(\omega) / 2\pi$
    - b)  $f(-\omega) / 2\pi$
    - c)  $2\pi f(-\omega)$
    - d) none of the above

- 6 The purpose of Design for Test (DFT) process in ASIC design flow is
- To capture functional errors
  - To capture manufacturing defects
  - To capture timing violations
  - For radiation mitigation

- 7 The coupling between the two inductors is increased from zero in the circuit shown. Which of the following statements is true?

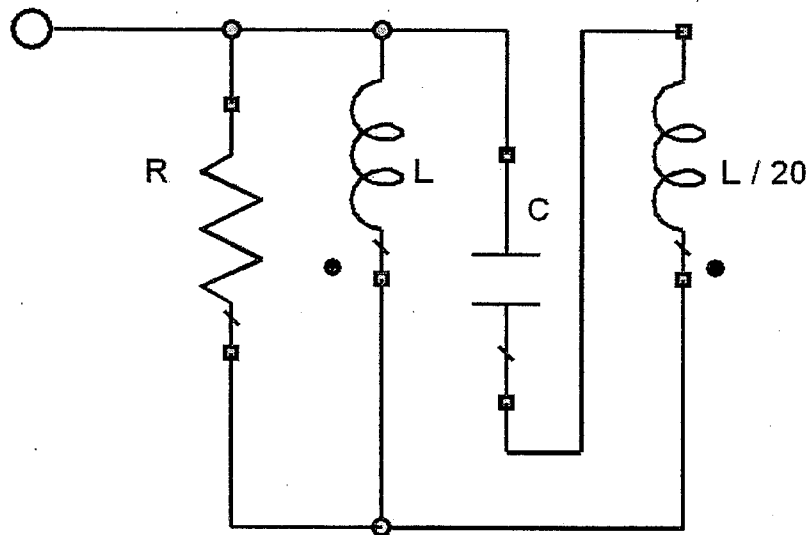

- The resonant frequency will increase and the Q will decrease
- The resonant frequency and Q will both increase.
- The resonant frequency and Q will both decrease
- The resonant frequency will decrease and the Q will increase

- 8 Write a Boolean expression for Z in terms of A, B, C, D and E. You need not simplify the expression.

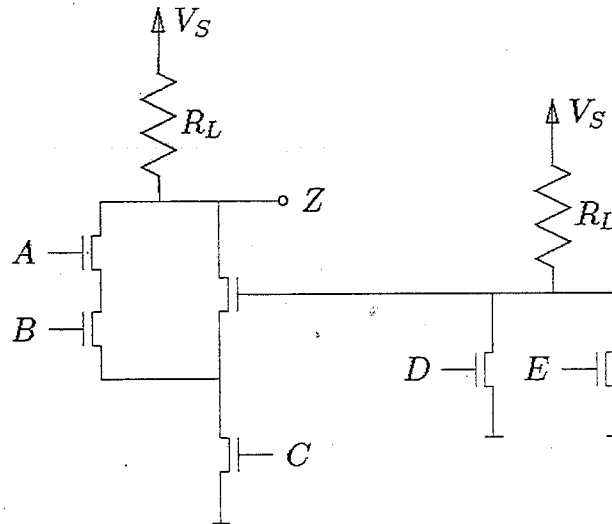

- a)  $\overline{\overline{\{(A + B) \cdot (D \cdot E)\} + C}}$
- b)  $\overline{\overline{\{(A \cdot B) + (D + E)\} \cdot C}}$
- c)  $\overline{\overline{\{(A \cdot B) + (D + E)\} \cdot \bar{C}}}$
- d) False
- 9 A parallel plate capacitor of 100 pf having an air dielectric is charged to 10 kilovolts. It is then electrically isolated. The plates are pulled away from each other until the distance is ten times more than before. Estimate the energy needed to pull the plates.
- a) 0.05 Joules                      b) 50 Joules
- c) 500 Joules                         d) -50 Joules
- 10 How could Schroedinger's equation be relevant in the practical design of a Cathode-Ray Tube?
- a) To optimize the colour quality
- b) To optimize the picture sharpness
- c) It is not relevant, because the CRT contains no crystalline lattice structure
- d) Its effects are negligible, as the electron wavelength is very small compared to the spot size



- 11 When compared with stripline, the major disadvantage of microstrip line is
- Not amenable for printed circuit technique.
  - More expensive and complex to manufacture.
  - Bulkier and voluminous.
  - More likely to radiate.
- 12 The disadvantage of single-stub matching as compared to double-stub matching, is that
- The stub position has to be adjustable
  - Only shunt stub can be used
  - Only resistive load can be matched
  - Useful only in two wire transmission line
- 13 A charge  $Q_2 = 8.854 \times 10^{-9}$  C is located in a vacuum at  $P_2 (2,3,1)$ . The force on  $Q_2$  due to a charge  $Q_1 = 4\pi \times 10^{-3}$  C at  $P_1 (2,2,1)$  is
- $a_y$  N
  - $-5.4a_x + 6.3a_y - 5.4a_z$  N
  - $5.4a_x - 6.3a_y - 5.4a_z$  N
  - None
- 14 If a material contains  $10^{20}$  molecules/m<sup>3</sup>, each molecule having a moment of  $8.854 \times 10^{-27}$  C-m parallel to an electric field of  $10^5$  V/m, then its dielectric constant is
- 2.2
  - 2
  - 4
  - 12
- 15 If every minor of order 'r' of a matrix 'A' is zero, then rank of 'A' is
- greater than 'r'
  - equal to 'r'
  - less than or equal to 'r'
  - less than 'r'
- 16 Which of the following is true
- The product of the eigenvalues of a matrix is equal to the trace of the matrix
  - The eigenvalues of a skew-symmetric matrix are real
  - A is a nonzero column matrix and B is a nonzero row matrix, then rank of AB is one
  - A system of linear non-homogeneous equations is consistent if and only if the rank of the coefficient matrix is less than or equal to the rank of the augmented matrix

- 17 What is the maximum clock frequency at which following circuit can be operated without timing violations? Assume that the Combinational logic delay is 10 ns and the clock duty cycle varies from 40% to 60 %.

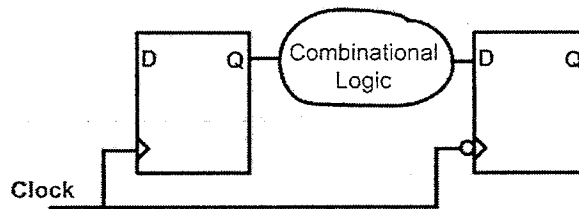

- a) 100 MHz      b) 50 MHz      c) 40 MHz      d) 25 MHz
- 18 Following shift register is initially loaded with the bit pattern "1010". After how many clock cycles will the content of shift register be "1010" again?

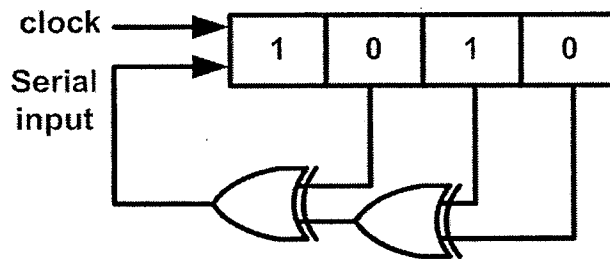

- a) 5      b) 9      c) 7      d) 15
- 19 Which one of the following is the lowest level of abstraction for representation of a digital system?
- a) VHDL/Verilog  
b) GDS-II  
c) Gate level netlist  
d) SystemC
- 20 The content of the accumulator of 8085 microprocessor after execution of the following instructions will be
- MVI A, A7h  
ORA A  
RLC

- a) FFh      b) 4Fh      c) 3Fh      d) CEh

- 21 For CMOS implementation of 2 input XOR logic gate, how many nMOS and pMOS transistors are required?  
 a) 2 nMOS and 2 pMOS  
 b) 3 nMOS and 3 pMOS  
 c) 6 nMOS and 6 pMOS  
 d) 8 nMOS and 8 pMOS
- 22 Which of the following principles is applied while designing the output matching network for a high power Class-C amplifier?  
 a) Maximum Power Transfer Theorem  
 b) Norton's Theorem  
 c) Thevenin's Theorem  
 d)  $\text{Power} = (\text{voltage})^2 / R_L$
- 23 Find the approximate output impedance of the VCCS (voltage-controlled current source) based circuit at port  $V_o$ .

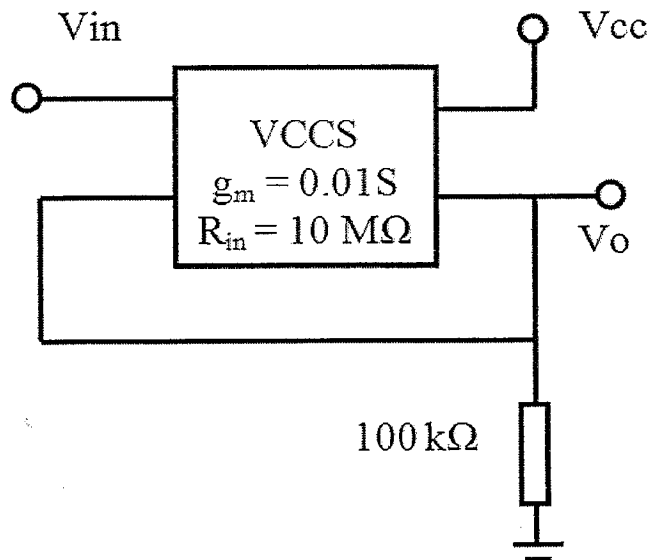

- a)  $0.01\ \Omega$                       b)  $100\ \Omega$                       c)  $100\text{ k}\Omega$                       d)  $10\text{ M}\Omega$
- 24 Which of the following parameters of a Silicon Schottky Diode is higher than that of a corresponding PN junction diode?  
 a) Forward voltage drop  
 b) Reverse recovery current  
 c) Reverse recovery time  
 d) Reverse leakage current

- 25 Assume the intrinsic standoff ratio for the UJT is 0.8 for the relaxation oscillator circuit given below. The frequency of oscillation of this circuit is approximately equal to

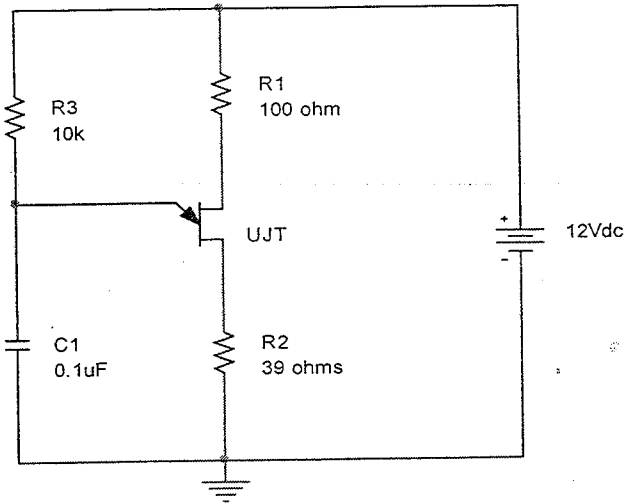

- a) 1.43 kHz      b) 620 Hz      c) 7kHz      d) 1.6kHz

- 26 The approximate frequency of oscillation of the circuit shown below is

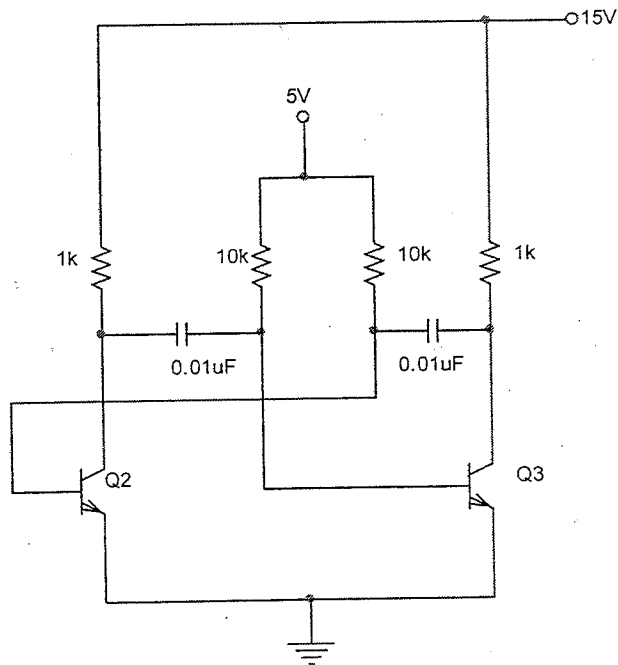

- a) 8.3kHz      b) 16.6kHz      c) 7.2kHz      d) 3.6kHz



- 27 A unit step voltage travels from left to right along an infinite transmission line. It hits an inductive discontinuity at  $t=0$ . What will be the waveform immediately to the left of the discontinuity?
- a) Positive spike on a unit step  
b) Unit step with reduced rise time  
c) Attenuated unit step  
d) Magnified unit step
- 28 A lossy open stub having a length of  $1/32$  wavelength, is approximately equivalent to
- a) A small capacitor in shunt with a small resistor  
b) A small capacitor in shunt with a large resistor  
c) A small inductor in shunt with a small resistor  
d) A large inductor in shunt with a large resistor
- 29 Ampere's law relates
- a) Electric field and Charge  
b) Electric field and Current  
c) Magnetic field and Current  
d) Magnetic field and Charge
- 30 Across which type of boundary does the electric field have a continuous tangential component?
- a) Charge free boundary  
b) Current free boundary  
c) Any boundary  
d) Charged boundary
- 31 Laplace Transform of  $e^{at}t^n$  is
- a)  $n/(s-a)^{n+1}$   
b)  $n!/(s+a)^{n+1}$   
c)  $n!/(s-a)^{n+1}$   
d)  $1/(s-a)^{n+1}$
- 32 For  $-\infty < x < \infty$  &  $-1 < y < 1$ , the partial differential equation  $x^2 \frac{\partial^2 u}{\partial x^2} + (1-y^2) \frac{\partial^2 u}{\partial y^2} = 0$  is
- a) parabolic  
b) Hyperbolic  
c) Elliptic  
d) Nature cannot be predicted
- 33 A CMOS digital circuit consumes P watts of dynamic power while operating at 20 MHz clock frequency and 5V supply. What will be its dynamic power consumption if the clock frequency is increased to 40 MHz and supply voltage is decreased to 2.5V?
- a) P/4  
b) P/2  
c) P  
d) 2P



- 34 A communication channel with Additive White Gaussian Noise, has a bandwidth of 4 kHz and SNR of 31dB. Its channel capacity is  
 a) 1.6 kbps                      b) 20 kbps                      c) 32 kbps                      d) 256 kbps
- 35 If the total power of an amplitude modulated signal is 600W and the carrier power is 400W, the modulation index is  
 a) 0.75                      b) 0.5                      c) 0.25                      d) 1
- 36 What is the advantage of Offset QPSK (OQPSK) compared to conventional QPSK?  
 a) Constant envelope                      b) Bandwidth efficiency  
 c) Simple demodulator                      d) All of above
- 37 An angle modulated signal with carrier frequency  $\omega_c = 2\pi \times 10^5$  is described by the equation  $s(t) = 10 \cos(\omega_c t + 5 \sin(3000\pi t) + 10 \sin(2000\pi t))$ . What is the frequency deviation  $\Delta f$ ?  
 a) 12387.32 Hz                      b) 17500 Hz                      c) 20000 Hz                      d) 15000 Hz
- 38 The Fourier transform of a signal  $x(t) = e^{-4|t|}$  is  
 a)  $8/(16 + \omega^2)$                       b)  $-8/(16 - \omega^2)$   
 c)  $4/(16 + \omega^2)$                       d)  $-4/(16 + \omega^2)$
- 39 What is the output waveform  $V_o$  for a sinusoidal input of peak-peak amplitude of 4V. Assume that Z1 and Z2 are two identical Zener diodes of 4.7V, and  $R_1=10\text{kohm}$  and  $R_2=20\text{kohm}$ .

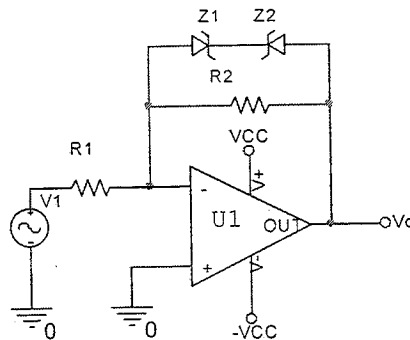

- a) Same as input  
 b) Sinusoidal waveform with 5.4V peak  
 c) Sinusoidal waveform clamped to +/- 4.7V  
 d) Sinusoidal waveform clamped to +/- 5.4V

- 40 For a particular toroidal inductor core, the inductance value obtained for 50 Turns is  $200\mu\text{H}$ . If two such inductors are wired in parallel, the resulting inductance is  
 a)  $200\mu\text{H}$                       b)  $50\mu\text{H}$                       c)  $400\mu\text{H}$                       d)  $100\mu\text{H}$
- 41 The magnetic equivalent of Ohm's Law is  
 a) Lenz's Law    b) Faraday's Law  
 c) Rowland's Law    d) Maxwell's Law
- 42 It is required to design a class B output stage (as shown below) to deliver an average output power of  $12.5\text{W}$  to a load of  $4\Omega$ . The power supply is selected so that  $V_{cc}$  is  $5\text{V}$  greater than the peak output voltage. Determine the power conversion efficiency of the circuit.

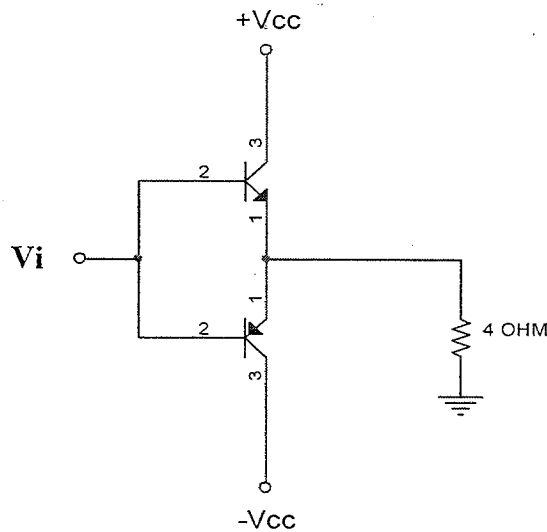

- a) 48%                      b) 50%                      c) 52%                      d) 54%

43 Which type of circuit has an input impedance as shown in this polar plot?

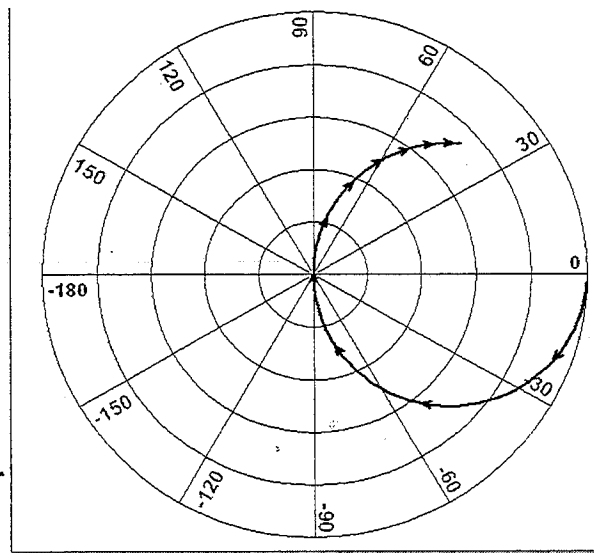

- (a) A resistance, capacitor and inductor in series
  - (b) A resistance, capacitor and inductor in parallel
  - (c) A resistance in shunt with a series combination of an inductor and a capacitor
  - (d) A resistance in series with a shunt combination of an inductor and a capacitor
- 44 A coaxial transmission line carrying an RF signal is perfectly matched to the load. Consider the cross-section of the line, at a plane where the instantaneous voltage is at its maximum value. How will the curl of the E-field vary over this cross-section?
- a) Increases from the center to the outer conductor
  - b) Decreases from the center to the outer conductor
  - c) Zero everywhere
  - d) Constant value proportional to the RF voltage
- 45 The continuity of the tangential field component at the interface of two media for normal incidence of a plane wave requires
- a)  $T = 1 - \Gamma$
  - b)  $T = 1 + \Gamma$
  - c)  $T = \Gamma$
  - d)  $T \neq \Gamma$
- 46 Which mode of a circular waveguide will have the lowest attenuation?
- a)  $TE_{11}$  Mode
  - b)  $TM_{01}$  Mode
  - c)  $TE_{21}$  Mode
  - d)  $TE_{01}$  Mode
- 47 If  $\phi = 2x^2y - xz^3$ , then the Laplacian of  $\phi$  is
- a)  $4yz - 6xz$
  - b)  $4z - 6xy$
  - c)  $4y - 6xz$
  - d)  $2xy - 6yz$

	<b>INDIAN SPACE RESEARCH ORGANISATION</b>	Page:
		<b>12 OF 18</b>
<b>2010</b>	<b>ELECTRONICS AND COMMUNICATION ENGINEERING</b>	<b>SET - A</b>

48 What does the following integral evaluate to?

$$\int_0^{\pi/2} \sin^6 \theta \cdot d\theta$$

- a)  $5\pi/16$                       b)  $5\pi/8$                       c) 0                      d)  $5\pi/32$
- 49 A signal with two frequency components at 6 kHz and 12 kHz, is sampled at the rate of 16 kHz and then passed through a Low Pass filter having a cut-off frequency of 16 kHz. The output signal of the filter
- a) is an undistorted version of the original signal  
b) contains the 6 kHz component and a spurious component of 4 kHz  
c) contains only the 6 kHz components  
d) contains both the components of the original signal and two spurious components of 4 kHz and 6 kHz
- 50 What is the greatest allowable PRF for unambiguous reception in a radar having a maximum range of 120 km?
- a) 1250 pps                      b) 2500 pps                      c) 1200 pps                      d) 5000 pps
- 51 A microprocessor has a cache memory with access time of 2 ns and a main memory with access time of 10 ns. If the cache miss ratio is 0.6, what is the average memory access time?
- a) 6.8 ns                      b) 6 ns                      c) 5.2 ns                      d) 12 ns
- 52 Consider the following assembly code for a hypothetical RISC processor with a 4-stage pipeline (Instruction Fetch, Decode/Register Read, Execute and Write).
- ```

add r1,r2,r3 // r1 = r2+r3
sub r4,r1,r3 // r4 = r1-r3
mul r5,r2,r3 // r5 = r2*r3

```
- Identify the possible pipeline hazard and the affected instruction.
- a) Read after write hazard during mul  
b) Read after write hazard during sub  
c) Read after write hazard during add  
d) Write after write hazard during mul
- 53 A zero memory source emits six messages with probabilities 0.3, 0.25, 0.15, 0.12, 0.1 and 0.08. If binary Huffman coding is used, what will be the average code length?
- a) 2.45 bits                      b) 3.45 bits                      c) 2.54 bits                      d) 3.54 bits

- 54 In the circuit given below, assume that  $V_{CC} = 15V$ ;  $Z_1, Z_2, Z_3$  &  $Z_4$  are identical zener diodes with breakdown voltage of  $5V$ ;  $R_1 = R_4 = 5k\Omega$ ,  $R_2 = R_3 = 10k\Omega$ . Find  $V_o$  when  $Q_1$  is OFF.

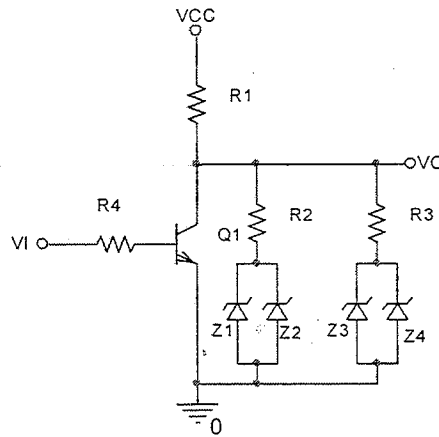

- a) 7.5 V                      b) 5V                      c) 10V                      d) 8.33V

- 55 Assume that  $V_i = 2V$ ;  $R_3 = 10\Omega$ ;  $\beta$  of  $Q_1 = 50$ ;  $V_{CC} = 15V$ . Find  $I_{out}$ .

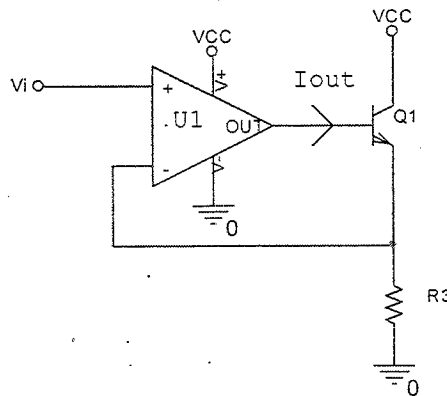

- a) 3.92mA                      b) 4mA                      c) 6.84mA                      d) 2.8mA

- 56 A sample and hold amplifier is connected to an ADC. The acquisition time of the sample and hold amplifier is  $10 \mu\text{sec}$  and the conversion time of the ADC is  $15 \mu\text{sec}$ . What is the highest possible data rate?

- a) 100 ksamples                      b) 400 ksamples                      c) 40 ksamples                      d) 66 ksamples

- 57 In an inverting OP-AMP, the input bias current is  $-1\mu\text{A}$ , and the input and the feedback resistances are both  $1\text{M}\Omega$ . What will be the output voltage for an input voltage of  $2.5\text{V}$ ?
- a)  $-2.5\text{V}$       b)  $-3.0\text{V}$       c)  $-3.5\text{V}$       d)  $4.0\text{V}$
- 58 Which of the following devices can be used for generating a PWM signal?
- a) Comparator      b) 555 timer  
c) Counter and magnitude comparator      d) All the above
- 59 A microwave receiving antenna on a satellite is pointing towards the earth. The antenna beamwidth is 50 degrees. The earth subtends 5 degrees at the satellite. What will be the noise temperature of the antenna?
- a) 30 degrees Kelvin      b) 5 degrees Kelvin  
c) 300 degrees Kelvin      d) 1000 degrees Kelvin
- 60 Estimate the magnitude and phase of the element  $S_{11}$  of the S-matrix of the circuit shown below. Assume an operating frequency of 25 MHz.

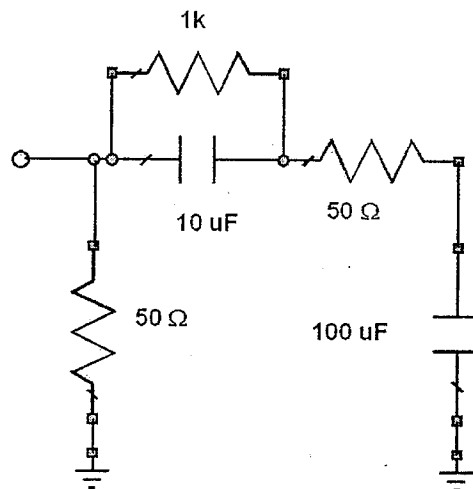

- a)  $25 \angle 180^\circ$       b)  $25 \angle 0^\circ$       c)  $0.33 \angle 180^\circ$       d)  $0.33 \angle 0^\circ$
- 61 The electric field measured in the far field of an antenna at a distance of 50m is  $1\text{V/m}$ . The average power density at a distance of 500m from the antenna is
- a)  $26.6\mu\text{W/m}^2$       b)  $0.1\mu\text{W/m}^2$       c)  $10\mu\text{W/m}^2$       d)  $13.3\mu\text{W/m}^2$
- 62 A quarter wave monopole antenna is situated above a perfectly conducting ground plane. It is driven by a 50V source at 500MHz through an internal impedance of  $63.5\Omega$ . The average power radiated by the antenna is
- a)  $39.37\text{W/m}^2$       b)  $4.56\text{W/m}^2$       c)  $68.49\text{W/m}^2$       d)  $45.6\text{W/m}^2$

- 63 Directional derivative of  $U=2x^3y-3y^2z$  at  $P(1,2,-1)$  in a direction towards  $Q(3,-1,5)$  is  
a)  $-90/7$                       b)  $30/7$                       c)  $90/49$                       d) None of the above
- 64 Consider the equation  $\text{Re}(1/z)=c$ , where  $z$  is a complex number,  $c$  is a nonzero constant and  $\text{Re}()$  represents the real part. The equation describes a  
a) Straight line              b) Parabola                      c) Circle                      d) None of the above
- 65 How many adders are required to realize a 256 point radix-2 FFT using decimation-in-time?  
a) 256                      b) 1024                      c) 4096                      d) 2048
- 66 A uniformly distributed random signal  $x[n]$  with mean  $m_x=2$  and variance  $\sigma_x^2=3$ , is passed through a 3-point moving-average filter having an impulse response  $\{h[n]\}=\{1/3, 1/3, 1/3\}$ . What will be the mean and variance of output?  
a)  $m_y=2, \sigma_y^2=1$                       b)  $m_y=2, \sigma_y^2=3$   
c)  $m_y=1, \sigma_y^2=1$                       d)  $m_y=3, \sigma_y^2=3$
- 67 A sine wave is applied to a balanced modulator. The peak output envelope power is 1000 times the minimum output envelope power. Estimate the carrier suppression in dBc.  
a) 24 dBc                      b) 30 dBc                      c) 36 dBc                      d) 40 dBc
- 68 Consider a single error correcting (7, 4) cyclic code with generator matrix  $g(x) = x^3 + x^2 + 1$ . What will be the transmitted data if received vector  $r$  is 1101101?  
a) 1100                      b) 1010                      c) 0001                      d) 1110
- 69 Consider a Golay's (23,12) code with  $t$  bits of error correction capability. For what value of  $t$  will the code exactly satisfy the Hamming bound ?  
a) 2                      b) 3                      c) 4                      d) 5
- 70 The maximum range of a monostatic Radar is  $R$ . If a target having a Radar cross-section of  $10\text{m}^2$  exists at  $R/2$ , what should be the target cross-section at  $3R/2$  to result in an equal signal strength at the Radar?  
a)  $90\text{m}^2$                       b)  $270\text{W}/\text{m}^2$                       c)  $810\text{m}^2$                       d)  $30\text{W}/\text{m}^2$
- 71 The electric field intensity at a distance of 10km from an antenna having a directive gain of 10dB and radiating a total power of 60kW is  
a)  $0.6\text{V}/\text{m}$                       b)  $1.2\text{V}/\text{m}$                       c)  $0.36\text{V}/\text{m}$                       d)  $13.3\mu\text{W}/\text{m}^2$

- 72 What is the characteristic impedance of a coaxial transmission line having inner conductor radius of 1mm, outer conductor radius of 2mm and dielectric constant of 4.0?  
 a) 50 ohm                      b) 60 ohm                      c) 20.62 ohm                      d) none
- 73 An impedance of  $-10 - j2$  ohms is connected to another impedance of  $45 + j5$  ohms through a transmission line having a characteristic impedance of 50 ohms. Assess the stability of this circuit.  
 a) Highly stable  
 b) Stability cannot be determined from the given information  
 c) Highly unstable  
 d) Marginally unstable
- 74 A transmission line of characteristic impedance 75 ohms is terminated with an impedance of 50 ohms. The line length is increased from zero. What will be the locus of the input impedance at the other end of the line? (N.B. : Reference impedance of Smith Chart = 50 Ohms)

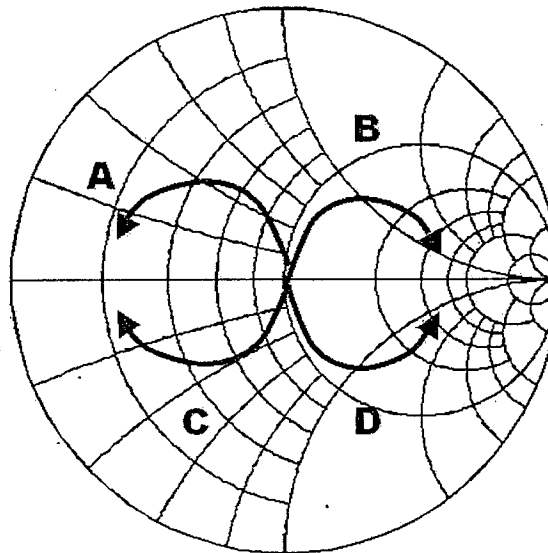

- a) Locus [A]                      b) Locus [B]                      c) Locus [C]                      d) Locus [D]

- 75 The value of the integral  $\int \sin z/z^3 \cdot dz$  around the circle  $|z|=2$  is  
 a) 1                      b) 0                      c) -1/2                      d) 1/2



76 Which of the following functions have a jump discontinuity at  $x=0$

a)  $g(x) = \ln |x|$

b)  $g(x) = 1/x^2$

c)  $\begin{cases} \frac{\sin(x)}{x}, & x \neq 0 \\ 0, & x = 0 \end{cases}$

d) None of the above

77 What would be the output of the following circuit, if a positive going unipolar pulse with an amplitude greater than  $V_{ref}$ , is applied at the input?

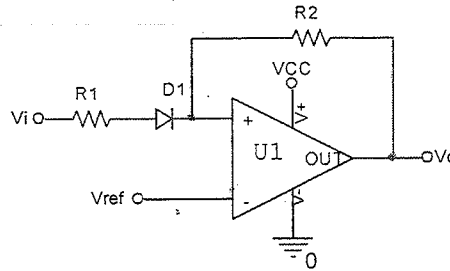

- a)  $V_o$  will go high momentarily and return to low
- b)  $V_o$  will go low momentarily and return to high
- c)  $V_o$  will go high and remain high
- d)  $V_o$  will not change its previous state

78 What is the output voltage across the 900 ohm load in the circuit given below?

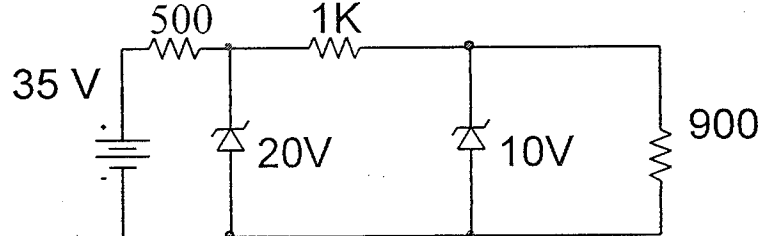

- a) 10V
- b) 14.67V
- c) 20V
- d) 9.47V

79 What is the transfer function of the network given below?

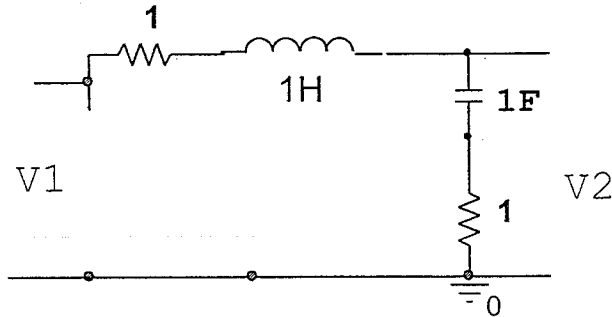

- a)  $(s + 1)/(2s + 1)$       b)  $1/(1+s)$       c)  $1/(2s + 1)$       d)  $1/(s^2 + 2s + 1)$

80 A voltage regulator having  $V_{ref}=1.25V$  needs to generate 5V output. Assume that  $I_{adj} = 100\mu A$  and  $R_1 = 10k\Omega$ . What should be value of  $R_2$ ?

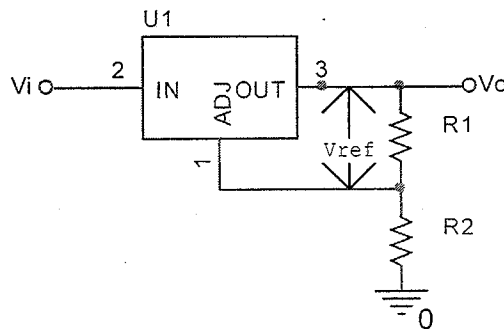

- a) 30 kohm      b) 33.33 kohm      c) 16.66kohm      d) 22.22 kohm