

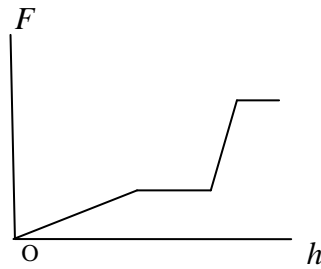

- 1 The figure , on the right, shows a jar filled with two liquids of densities  $\rho$  and  $\rho/2$  that do not mix. A cylinder made of a material of density  $3\rho/4$  is held in the jar at various depths starting from the position where the lower surface of the cylinder touches the upper surface AB of the liquid. Which of the following schematic curves best describes the buoyancy force  $F$  on the cylinder as a function of the displacement  $h$  from the starting position?

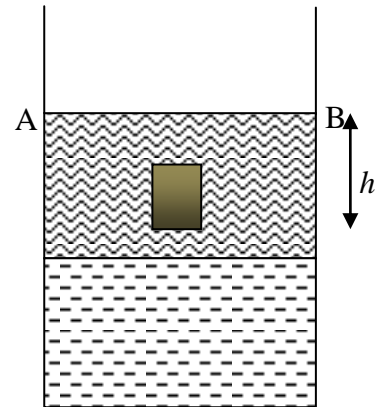

(a)

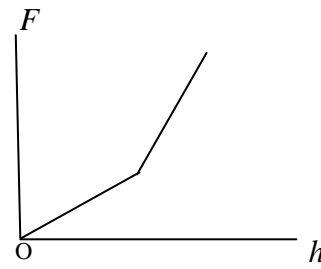

(b)

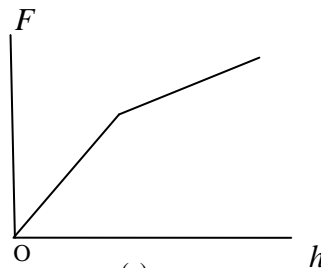

(c)

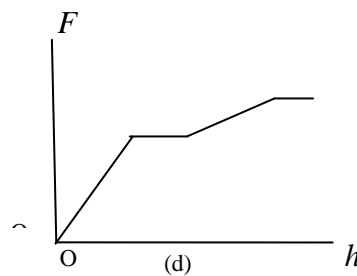

(d)



2. An infinitely large surface of uniform charge density  $\sigma$  has a disc of radius  $R$  cut out (see figure). The magnitude of the electric field at a distance  $a$  above the centre of the disc is given by

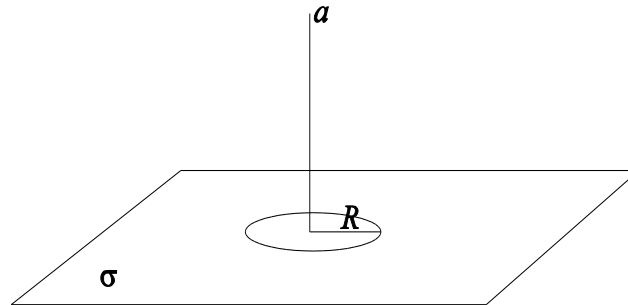

- (a)  $\frac{\sigma}{2\epsilon_0} \frac{a^2}{R^2 + a^2}$
- (b)  $\frac{\sigma}{\epsilon_0} \frac{a}{\sqrt{R^2 + 4a^2}}$
- (c)  $\frac{\sigma\pi}{2\epsilon_0} \frac{a}{\sqrt{R^2 + \pi^2 a^2}}$
- (d)  $\frac{\sigma}{2\epsilon_0} \frac{a}{\sqrt{R^2 + a^2}}$

3. All the five capacitors shown in the figure have the same capacitance  $C$ . The battery has emf  $V$ . The charge on the capacitor  $T$  is

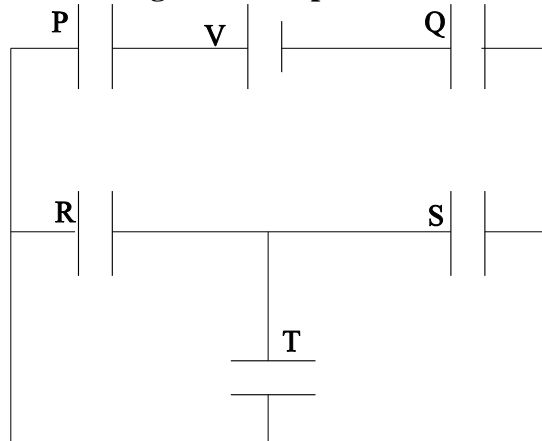

- (a) zero
- (b)  $CV$
- (c)  $CV/3$
- (d)  $CV/5$



4. The figure shows a wire mesh of infinite extent, such that the resistance between any two neighbouring vertices is equal. A steady current of 1A flows into the node  $P$ , from a current source, while a steady current of 1A is extracted from the node  $Q$ , as shown. Regard the situation as the superposition of two processes: the first in which the current flows into the mesh, and the second in which it flows out of the mesh. The steady current flowing in the segment  $PQ$  is equal to

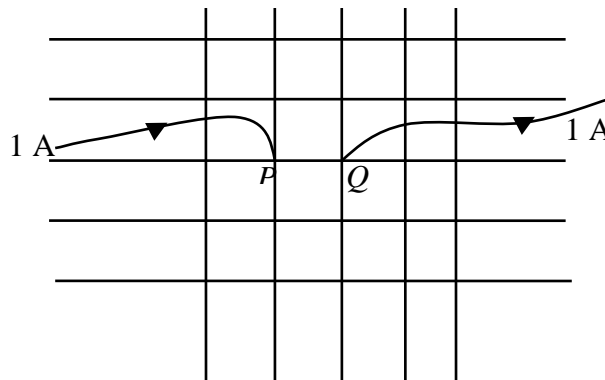

- (a) 2 A (b) 1 A  
(c) 1/2 A (d) 1/4 A
5. In a Young's double slit experiment, the separation between the slits is 1.0 mm and the distance between the slits and the screen is 1.0 m. The light falling on the slits contains mainly two wavelengths 600 nm and 500 nm. The least distance from the centre of the fringe pattern where the intensity corresponding to one of these wavelengths is zero, is
- (a) 0.30 mm (b) 0.75 mm  
(c) 0.25 mm (d) 1.20 mm
6. The electric field  $\vec{E}(\vec{r}, t)$  and the magnetic field  $\vec{B}(\vec{r}, t)$  of a plane electromagnetic wave propagating in free space along the x-axis are given by

$$\vec{E}(\vec{r}, t) = E_0 \hat{i} \cos(\omega t - kz) \text{ and } \vec{B}(\vec{r}, t) = B_0 \hat{j} \cos(\omega t - kz)$$

where  $B_0 = E_0/c$ ,  $k$  is the wave number, and  $\omega$  is the (angular) frequency. The average value of the vector  $\frac{1}{\mu_0}(\vec{E} \times \vec{B})$  over a full time period of the wave is

(a) 0	(b) $\frac{cB_0^2}{\mu_0} \hat{k}$
(c) Infinity	(d) $\frac{c}{2} \epsilon_0 E_0^2 \hat{k}$

7. A transverse wave travels on a taut string stretched along the x-axis. The linear mass density of the string varies slowly with  $x$  as  $\mu = \mu_0 + \alpha x$  where  $\mu_0$  and  $\alpha$  are positive constants. As a result, both the amplitude and the wavelength become functions of  $x$ . As the wave travels down the string, its energy content over one wavelength, averaged over a time period is independent of  $x$ . The graph of the amplitude  $A(x)$  versus  $x$  should be like

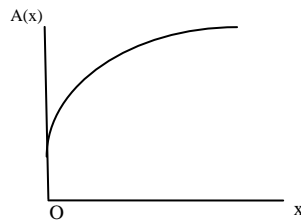

(a)

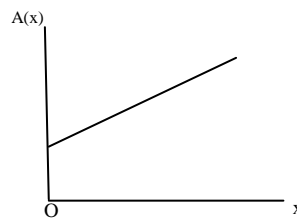

(b)

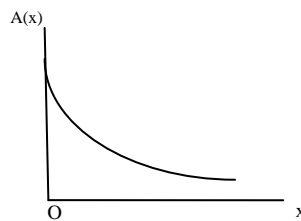

(c)

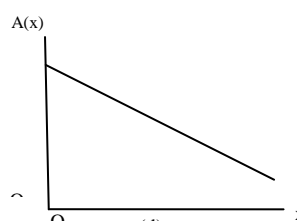

(d)

8. A spherical soap bubble of radius  $R$  is

blown from a tiny drop of soap solution. If the surface tension of the soap film is  $T$ , the work required to make the bubble is

(a)  $2\pi TR^2$   
(c)  $6\pi TR^2$

(b)  $4\pi TR^2$   
(d)  $8\pi TR^2$

9. In a column of air at a given temperature  $T$ , the density  $\rho$  is found to vary with the

altitude  $z$  above ground level according to  $\rho(z) = \rho_0 \exp\left(-\frac{mgz}{k_B T}\right)$ , where  $\rho_0$  is a

positive constant,  $m$  is the mass of a molecule of air,  $g$  is the acceleration due to gravity, and  $k_B$  is Boltzmann's constant. The density  $\rho(z)$  of molecules is proportional to the probability of finding molecules at height  $z$ . The mean value of the height above ground level of an air molecule is therefore equal to

a)  $\frac{2k_B T}{mg}$

b)  $\sqrt{\frac{k_B T}{mg}}$

c)  $\frac{k_B T}{mg}$

d)  $\left(\frac{k_B T}{mg}\right)^2$

**Comprehensive:** Questions no. 10 to 12

Experiments show that the number of nucleons (protons and neutrons) per unit volume inside a nucleus is fairly constant near its center, and gradually decrease in the outer region. The near constant of nucleon density results from the fact that each nucleon in a nucleus interacts only with a small number of nucleons in its surrounding through attractive nuclear force. The nucleon density  $\rho(r)$  as a function of the distance  $r$  from the center of the nucleus is approximately given by

$$\rho(r) = \frac{\rho_0}{1 + \exp\left[\frac{r - R}{a}\right]}$$

	<b>ISAT 2010</b> <b>INDIAN INSTITUTE OF SPACE SCIENCE AND TECHNOLOGY</b>	<b>Page</b> <b>5 OF 12</b>
	<b>PAPER I – PHYSICS, CHEMISTRY AND MATHEMATICS</b>	<b>SET - B</b>

where  $\rho_0 = 0.17 \text{ nucleon/fm}^3$ ,  $R = (1.1 \text{ fm}) A^{1/3}$  and  $a = 0.55 \text{ fm}$ . Here  $A = \text{mass number}$ .

10. The mass density in a nucleus near its center, in units of  $\text{kg/m}^3$ , is in the range
- (a)  $10^{15}$  to  $10^{20}$                       (b)  $10^5$  to  $10^{10}$   
(c)  $10^{10}$  to  $10^{15}$                       (d)  $10^{20}$  to  $10^{25}$
11. For the nucleus  $^{216}\text{Te}$ , the value of  $r$  for which the nucleon density falls to half its value at the centre is in the range
- (a) 7 to 8 fm                                  (b) 5 to 6 fm  
(c) 6 to 7 fm                                  (d) 8 to 9 fm
12. The plots of  $\rho(r)$  versus  $r$  for  $^{28}\text{Si}$  and another nucleus  $X$  are shown in the figure. The nucleus  $X$  could be

- (a)  $^{42}\text{Ca}$   
(b)  $^{94}\text{Zr}$   
(c)  $^{63}\text{Cu}$   
(d)  $^{142}\text{Ba}$

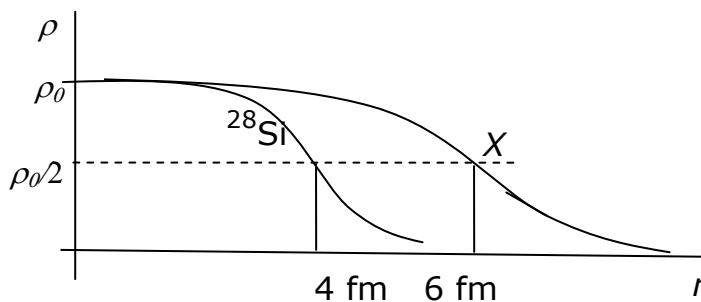



13. A block A with initial velocity  $\vec{V}_0$  strikes a spring tied to a block B identical to A, initially at rest (see figure). The spring is assumed to be massless. Friction may be neglected. At the instant of maximum compression of the spring, let the velocities of A and B be  $\vec{V}_1$  and  $\vec{V}_2$ , respectively.

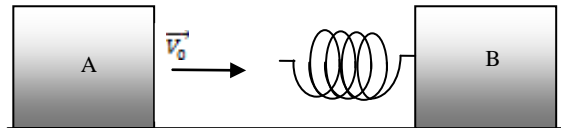

Then

- (a)  $\vec{V}_1 + \vec{V}_2 = \frac{\vec{V}_0}{2}$                       (b)  $V_1^2 + V_2^2 = V_0^2$   
 (c)  $\vec{V}_1 + \vec{V}_2 = \vec{V}_0$                       (d)  $V_1^2 + V_2^2 = \frac{V_0^2}{2}$

14. A particle moves in the first quadrant of the  $x$ - $y$  plane under the action of a force. It starts from the origin and moves on the path given by  $y = A \tan(x / x_0)$ , without turning back at any instant. The only possible time variation of the  $x$ -component of velocity  $v_x$  out of the four possibilities given below ( $u$  and  $t_0$  are positive constants) is

- (a)  $v_x = \frac{u}{2} \left[ 1 + \frac{1}{(1 + t / t_0)^2} \right]$   
 (b)  $v_x = u e^{-t/t_0}$   
 (c)  $v_x = u(1 + t / t_0)$   
 (d)  $v_x = u(2 - e^{-t/t_0})$

15. In a modified experiment, the photoelectric effect was studied with a sample of a multielectron atom. The result is represented by

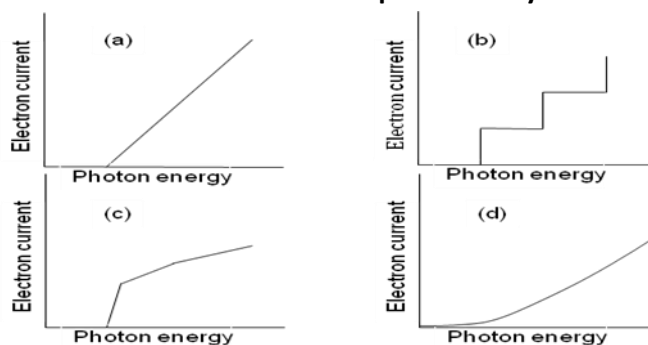

16. In the following statements,

- A. ideal gases are liquids only at very low temperatures
- B. ideal gases cannot be liquefied
- C. ideal gas behaviour is observed by real gases at low pressures

 <b>ISAT 2010</b>	<b>ISAT 2010</b> <b>INDIAN INSTITUTE OF SPACE SCIENCE AND TECHNOLOGY</b>	<b>Page</b> <b>7 OF 12</b>
	<b>PAPER I – PHYSICS, CHEMISTRY AND MATHEMATICS</b>	<b>SET - B</b>

D. ideal gases do not exist

The correct statements are

- (a) A, B, C & D  
 (b) A, B & C  
 (c) B, C & D  
 (d) C & D

17. The correct order for the rate of  $S_N1$  reactions for the following compounds is

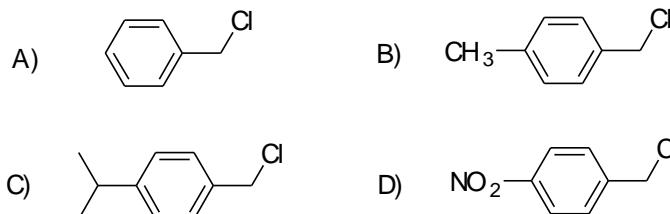

- (a)  $D > C > B > A$   
 (b)  $C > B > D > A$   
 (c)  $C > B > A > D$   
 (d)  $B > C > A > D$

18. The aromatic species among the following are

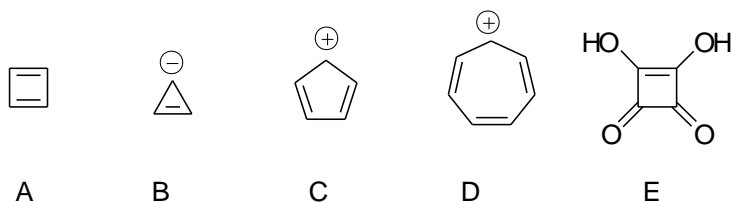

- (a) D & E  
 (b) A, B, D & E  
 (c) A, B & C  
 (d) B, D & E

19. The reactions that give products with dipole moment are

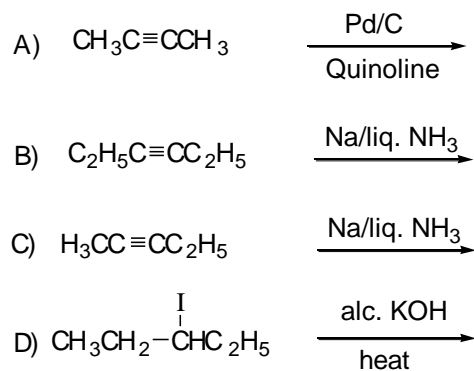

- (a) A & C  
 (b) B & C  
 (c) B, C & D  
 (d) A, C & D

20. The total number of stereoisomers for the following compound is

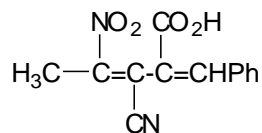

- (a) 10 (b) 6  
(c) 4 (d) 8

21. The correct order of ligand field strength is

- (a)  $\text{H}_2\text{O} < \text{Cl}^- < \text{CO} < \text{NH}_3$  (b)  $\text{CO} < \text{NH}_3 < \text{Cl}^- < \text{H}_2\text{O}$   
(c)  $\text{H}_2\text{O} < \text{CO} < \text{NH}_3 < \text{Cl}^-$  (d)  $\text{Cl}^- < \text{H}_2\text{O} < \text{NH}_3 < \text{CO}$

22. The complex exhibiting a spin-only magnetic moment ( $\mu_s$ ) of 2.87 B.M. is

- (a)  $[\text{Co}(\text{H}_2\text{O})_3\text{F}_3]$   
(b)  $\text{K}_4[\text{Fe}(\text{OH})_6]$   
(c)  $\text{Na}_2[\text{Cr}(\text{NCS})_4(\text{NH}_3)_2]$   
(d)  $\text{K}_2[\text{MnCl}_4(\text{H}_2\text{O})_2]$

23. The most stable species among the following is

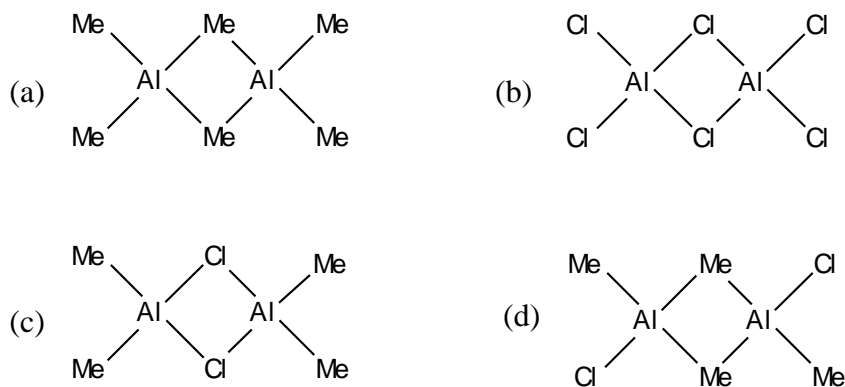

24. According to the VSEPR model, the most stable arrangement is

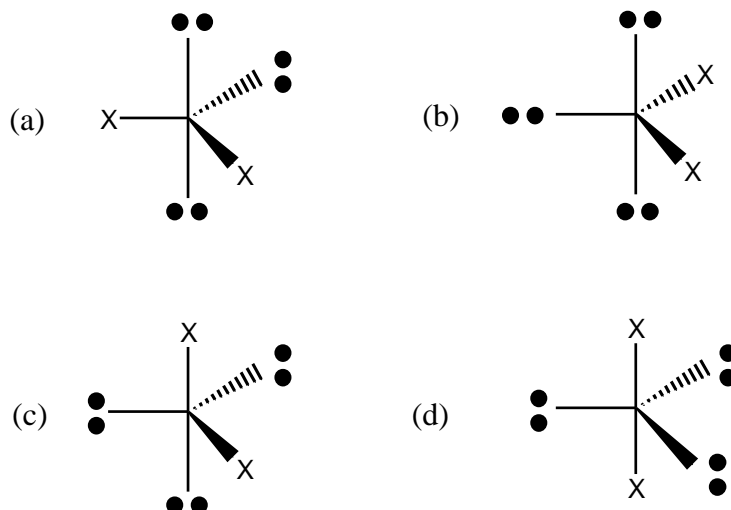



	<b>ISAT 2010</b> <b>INDIAN INSTITUTE OF SPACE SCIENCE AND TECHNOLOGY</b>	<b>Page</b>
		<b>9 OF 12</b>
<b>ISAT 2010</b>	<b>PAPER I – PHYSICS, CHEMISTRY AND MATHEMATICS</b>	<b>SET - B</b>

25. Cyclohexanol is converted to Nylon-6 by

- (a)  $\text{Na}_2\text{O}/\text{NH}_2\text{OH}/\text{H}^+/250^\circ\text{C}$
- (b)  $\text{Cu}(250^\circ\text{C})/\text{NH}_2\text{OH}/\text{H}^+/250^\circ\text{C}$
- (c)  $\text{Ag}_2\text{O}/\text{NH}_2\text{OH}/\text{H}^+/250^\circ\text{C}$
- (d)  $\text{Cu}(250^\circ\text{C})/\text{NH}_2\text{OH}/250^\circ\text{C}$

26. Some gases in column X may be associated with options in Y.

X	Y
$\text{CO}_2$	M. troposphere
$\text{CO}$	N. stratosphere
$\text{SO}_2$	O. smog
$\text{O}_3$	P. Carboxyhaemoglobin
	Q. photosynthesis
	R. acid rain

The correct answer is

- (a)  $\text{SO}_2 \rightarrow \text{M, O \& R}$
- (b)  $\text{CO}_2 \rightarrow \text{N, Q \& R}$
- (c)  $\text{CO} \rightarrow \text{M, P \& R}$
- (d)  $\text{O}_3 \rightarrow \text{N, P \& Q}$

27. A vessel, fitted with a weightless, frictionless piston of  $0.025 \text{ m}^2$  area, contains excess con. HCl. The piston moved 1 m outward when 0.075 kg of iron filings were added at 300 K. The solution left behind was found to contain Fe(II). The approximate purity of the iron sample is

- (a) 50 %
- (b) 75 %
- (c) 90 %
- (d) 40 %

28. A solution at 298 K is separated from the pure solvent by a semi-permeable membrane. Difference in the height of the solution and the solvent is 0.9 m. If  $K_f$  and freezing point of the solvent are  $30 \text{ K kg mol}^{-1}$  and 250.3 K, respectively, the temperature at which the solution freezes is

- (a) 250.10 K
- (b) 250.25 K
- (c) 250.20 K
- (d) 250.05 K

29. The number of real roots of the equation in the interval  $(1/(x-1)) + (1/(x-2)) + \dots + 1/(x-5) = 1$  in the interval (1,5) is

- (a) 5
- (b) 4
- (c) 3
- (d) 0

	<b>ISAT 2010</b> <b>INDIAN INSTITUTE OF SPACE SCIENCE AND TECHNOLOGY</b>	<b>Page</b>
		<b>10 OF 12</b>
<b>ISAT 2010</b>	<b>PAPER I – PHYSICS, CHEMISTRY AND MATHEMATICS</b>	<b>SET - B</b>

30. Let  $y$  be the solution of the problem  $y' - y = 1 + 5e^{-x}$ ,  $y(0) = y_0$ . If  $\lim_{x \rightarrow \infty} |y(x)|$  is finite, then  $y_0$  is

- a)  $-7/2$
- b)  $0$
- c)  $9$
- d)  $-11$

31. The distance from a point  $(k, 0)$  on the positive  $x$ -axis to the tangent to the parabola

$y^2 = 4x$  at  $(\frac{1}{4}, 1)$  is  $2\sqrt{5}$ . Then, the value of  $k$  is

- a)  $19/4$
- b)  $9/4$
- c)  $(4\sqrt{5} - 1)/4$
- d)  $(2\sqrt{5} - 1)/4$

32. The point  $(-3, 2)$  undergoes the following transformations successively:

- (i) Reflection about the line  $y = -x$
- (ii) Reflection about the line  $x = 0$
- (iii) Translation through a distance of 2 units along the negative direction of  $y$ -axis.
- (iv) Rotation through an angle  $\pi/4$  in the anti-clockwise direction about the origin.

Then, the position of the point is at

- a)  $(-\frac{1}{\sqrt{2}}, -\frac{3}{\sqrt{2}})$
- b)  $(-\frac{1}{\sqrt{2}}, \frac{3}{\sqrt{2}})$
- c)  $(\frac{1}{\sqrt{2}}, -\frac{3}{\sqrt{2}})$
- d)  $(\frac{1}{\sqrt{2}}, \frac{3}{\sqrt{2}})$

33. The equation of the plane passing through the intersection of the planes  $x + 2y + z - 1 = 0$  and  $2x + y + 3z - 2 = 0$  and perpendicular to the plane  $x + y + z - 1 = 0$  is  $x + ky + 3z - 1 = 0$ . Then, the value of  $k$  is

- (a) 4
- (b) -4
- (c) 2
- (d) -2

34. The principal value of  $\sin^{-1}(\sin \frac{5\pi}{9} \cos \frac{\pi}{9} + \cos \frac{5\pi}{9} \sin \frac{\pi}{9})$  is

- a)  $\frac{2\pi}{3}$
- b)  $\frac{\pi}{3}$

	<b>ISAT 2010</b> <b>INDIAN INSTITUTE OF SPACE SCIENCE AND TECHNOLOGY</b>	<b>Page</b>
		<b>11 OF 12</b>
<b>ISAT 2010</b>	<b>PAPER I – PHYSICS, CHEMISTRY AND MATHEMATICS</b>	<b>SET - B</b>

- c)  $\frac{4\pi}{9}$   
d)  $-\frac{\pi}{6}$

35. Four numbers are chosen at random without replacement from the first 15 natural numbers. Then the probability that their product is even is

- a)  $1 - \frac{8C_4}{15C_4}$   
b)  $\frac{8C_4}{15C_4}$   
c)  $\frac{7C_4}{15C_4}$   
d)  $1 - \frac{7C_4}{15C_4}$

36. Let  $M$  be a non-singular matrix of order  $5 \times 5$ . Then,  $|\text{adj} M^{-1}|$  is

- a)  $|M|^{-4}$   
b)  $|M|$   
c) 1  
d)  $|M|^4$

37. Let  $P = \begin{bmatrix} 1 & 2 & 0 \\ -1 & 1 & 2 \\ 1 & 2 & 1 \end{bmatrix}$  and  $Q$  be such that  $PQ = I$ . Then, the values of  $\lambda$  for which there

exists non-zero  $X = \begin{bmatrix} x_1 \\ x_2 \\ x_3 \end{bmatrix}$  satisfying  $QX = \lambda X$  are

- a)  $\frac{1}{3}, i, -i$   
b)  $3, i, -i$   
c)  $i, -i, 1$   
d) real numbers

38. The value of the determinant

$$\begin{vmatrix} x & a & a & a & a \\ a & x & a & a & a \\ a & a & x & a & a \\ a & a & a & x & a \\ a & a & a & a & x \end{vmatrix} \quad \text{is}$$

- a)  $(x+4a)(x-a)^4$

	<b>ISAT 2010</b> <b>INDIAN INSTITUTE OF SPACE SCIENCE AND TECHNOLOGY</b>	<b>Page</b>
		<b>12 OF 12</b>
<b>ISAT 2010</b>	<b>PAPER I – PHYSICS, CHEMISTRY AND MATHEMATICS</b>	<b>SET - B</b>

- b)  $(x-4a)(x-a)^4$   
c)  $(x+4a)^2(x-a)^3$   
d)  $(x-4a)^2(x-a)^3$

39. Let  $x$  be the  $7^{\text{th}}$  term from the beginning and  $y$  be the  $7^{\text{th}}$  term from the end in the expansion of  $(3^{1/3} + \frac{1}{4^{1/3}})^n$ . If  $\frac{x}{y} = \frac{1}{12}$ , then  $n$  is

- (a) 7 (b) 8  
(c) 9 (d) 10

40. The number of functions  $f: \{1,2,\dots,n\} \rightarrow \{1,2,\dots,m\}$ , where  $m, n$  are positive integers such that  $f(1) = 1$  is

- a)  $m^n - m^{n-1}$   
b)  $m^{n-1}$   
c)  $(m-1)^n$   
d)  $n^{m-1}$

End of Questions