

I B.Tech Regular Examinations, May/June 2008

ENGINEERING DRAWING

(Common to Electrical & Electronic Engineering, Electronics &
Instrumentation Engineering and Electronics & Computer Engineering)

Time: 3 hours

Max Marks: 80

Answer any FIVE Questions
All Questions carry equal marks

1. The vertex of a hyperbola is 65mm from its focus. Draw the curve if the eccentricity is $3/2$. Draw a normal and a tangent at a point on the curve, 75 mm from the directrix. [16]
2. Show by means of a drawing that when the diameter of the directing circle is twice that of the generating circle, the hypocycloid is a straight line. Take the diameter of the generating circle equal to 50mm. [16]
3. (a) A point A is 2.5 cm above the H.P. and 3 cm in front of the V.P. Draw its Projections.
(b) A point A is 2 cm below the H.P. and 4 cm behind the V.P. Draw its Projections.
(c) Two points A and B are in the H.P. The point A is 30mm in front of the V.P., while B is behind the V.P. The distance between their projectors is 75mm and the line joining their top views makes an angle of 45° with xy. Find the distance of the point B from the V.P. [4+4+8]
4. A line AB 120mm long is inclined at 45° to the H.P. and 30° to the V.P. Its mid point C is in V.P. and 20mm above H.P. The end A is in the third quadrant, and B is in the first quadrant Draw the projections of the line. [16]
5. (a) A regular pentagon of 25mm side has one side on the ground. Its plane is inclined at 45° to the H.P. and perpendicular to the V.P. Draw its projections.
(b) Draw the projections of a circle of 5cm diameter, having its plane vertical and inclined at 30° to the V.P. Its centre is 3cm above the H.P. and 2cm in front of the V.P. [8+8]
6. (a) Draw the projections of a hexagonal prism of base 25mm and axis 60mm long, when it is resting on one of its corners of the base on H.P. The axis of the solid is inclined at 45° to H.P.
(b) Draw the projections of a pentagonal prism of base 25mm side and axis 50mm long, when it is resting on one of its rectangular faces on H.P., the axis of the solid is inclined at 45° to V.P. [8+8]
7. Draw the isometric view of a Door-Steps having three steps of 22cm tread and 15cm rise. The steps measure 75cm widthwise. [16]

8. Draw the following views of the block shown in figure 8. All dimensions are in mm.

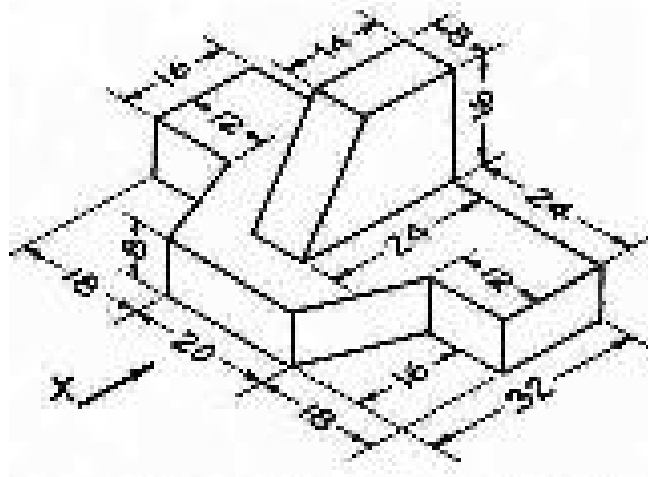

Figure 8

- (a) Front View.
- (b) Top view
- (c) Both side views.

[16]

I B.Tech Regular Examinations, May/Jun 2008

ENGINEERING DRAWING

(Common to Electrical & Electronic Engineering, Electronics &
Instrumentation Engineering and Electronics & Computer Engineering)

Time: 3 hours

Max Marks: 80

Answer any FIVE Questions
All Questions carry equal marks

1. The foci of an ellipse are 80mm apart and the minor axis is 55mm long. Determine the length of the major axis and draw the ellipse by concentric-circle method. Draw a curve parallel to the ellipse and 20mm away from it. [16]
2. A circle of 50mm diameter rolls on the circumference of another circle of 175mm diameter and outside it. Trace the locus of a point on the circumference of the rolling circle for one complete revolution. Name the curve. Draw a tangent and a normal to the curve at a point 125mm from the center of the directing circle. [16]
3. (a) A point A is 2.5 cm above the H.P. and 3 cm in front of the V.P. Draw its Projections.
(b) A point A is 2 cm below the H.P. and 4 cm behind the V.P. Draw its Projections.
(c) Two points A and B are in the H.P. The point A is 30mm in front of the V.P., while B is behind the V.P. The distance between their projectors is 75mm and the line joining their top views makes an angle of 45° with xy. Find the distance of the point B from the V.P. [4+4+8]
4. (a) A 100mm long line is parallel to and 40mm above the H.P. Its two ends are 25mm and 50mm in front of the V.P. respectively. Draw its projections and find its inclination with the V.P.
(b) A line AB, 50mm long, has its end A in both the H.P. and the V.P. Its is inclined at 30° to the H.P and at 45° to the V.P. Draw its projections. [8+8]
5. A circular plane of 60mm diameter, rests on V.P. on a point A on its circumference. Its plane is inclined at 45° to V.P. Draw the projections of the plane when
(a) The front view of the diameter AB makes 30° with H.P. and
(b) The diameter AB itself makes 30° with H.P. [16]
6. (a) Draw the projections of a triangular prism, base 40 mm side and axis 50 mm long, resting on one of its bases on the H.P. with a vertical face perpendicular to the V.P.
(b) A cube of 50mm long edges is resting on the H.P. with its Vertical faces equally inclined to the V.P. Draw its projections.

(c) A triangular prism, base 40 mm side and height 65 mm is resting on the H.P. on one of its rectangular faces with the axis parallel to the V.P. Draw its projections. [4+8+4]

7. Draw the isometric view of the ribbed angle plate, Shown in figure 7 All dimensions are in mm. [16]

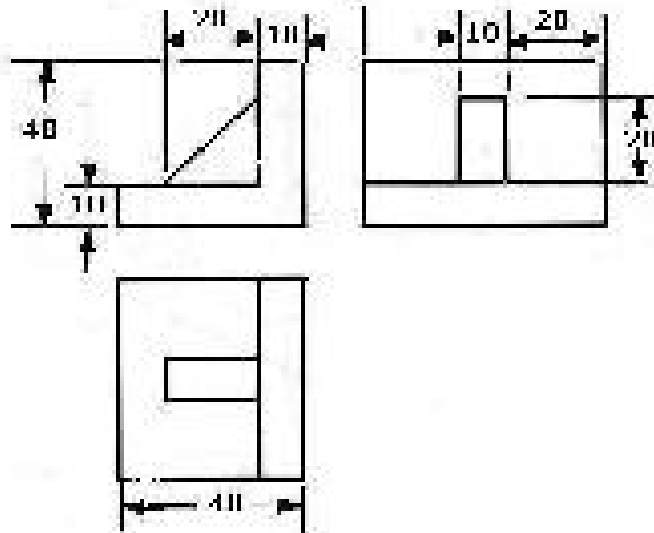

Figure 7

8. Draw the front view, top view and left side views of V- block as shown in figure.8. All dimensions are in mm [16]

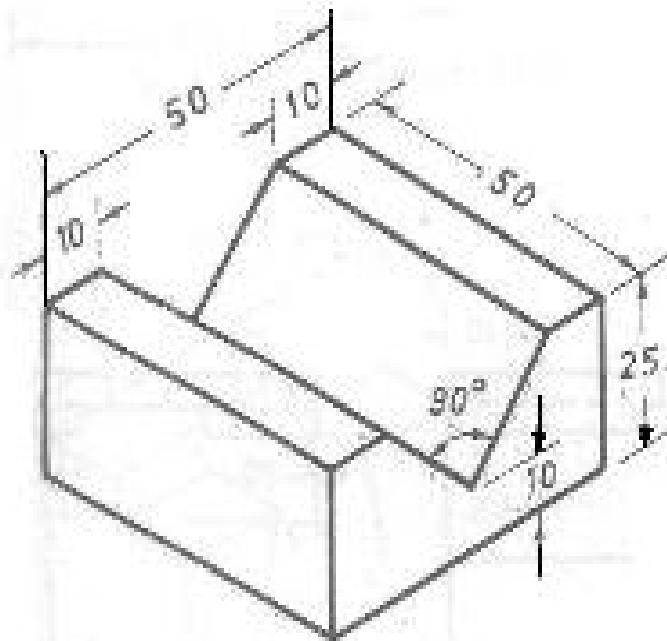

Figure 8

I B.Tech Regular Examinations, May/June 2008

ENGINEERING DRAWING

(Common to Electrical & Electronic Engineering, Electronics &
Instrumentation Engineering and Electronics & Computer Engineering)

Time: 3 hours

Max Marks: 80

Answer any FIVE Questions
All Questions carry equal marks

1. Two straight lines OA and OB make an angle of 75° between them. P is a point 40mm from OA and 50mm from OB. Draw a hyperbola through P, with OA and OB as asymptotes, marking at least ten points. [16]
2. A circle of 35mm diameter rolls on a horizontal line. Draw the curve traced out by a point R on the circumference for one half revolution of the circle. For the remaining half revolution, the circle rolls on the vertical line. The point R vertically above the center of the circle in the starting position. [16]
3. (a) A point P is 15mm above the H.P. and 20mm in front of the V.P. Another point Q is 25mm behind the V.P. and 40mm below the H.P. Draw projections of P and Q keeping the distance between their projectors equal to 90mm. Draw straight lines joining
 - i. their top views and
 - ii. their front views.(b) A point 30mm above xy line is the plan view of two points P and Q. the elevation of P is 45mm above the H.P. while that of the point Q is 35mm below the H.P. Draw the projections of the points and state their position with reference to the principal planes and the quadrant in which they lie. [8+8]
4. (a) A 100mm long line is parallel to and 40mm above the H.P. Its two ends are 25mm and 50mm in front of the V.P. respectively. Draw its projections and find its inclination with the V.P.
(b) A line AB, 50mm long, has its end A in both the H.P. and the V.P. Its is inclined at 30° to the H.P and at 45° to the V.P. Draw its projections. [8+8]
5. A regular hexagonal plane of 30mm side, has a corner at 20mm from V.P. and 50mm from H.P. Its surface is inclined at 45° to V.P. and perpendicular to H.P. Draw the projections of the plane. [16]
6. (a) Draw the projections of a pentagonal pyramid, base 30 mm edge and axis 50mm long, having its base on the H.P. and an edge of the base parallel to the V.P. Also draw its side view.
(b) Draw the projections of a hexagonal pyramid, base 30 mm side and axis 60 mm long, having its base on the H.P. and one of the edges of the base inclined at 45° to the V.P.

(c) A square pyramid, base 40mm side and axis 65mm, long has its base in the V.P. One edge of the base is inclined at 30° to the H.P. and a corner contained by that edge is on the H.P. Draw its Projections. [4+8+4]

7. Draw the isometric view of the block, two views of which are shown in figure 7. (All dimensions are in mm). [16]

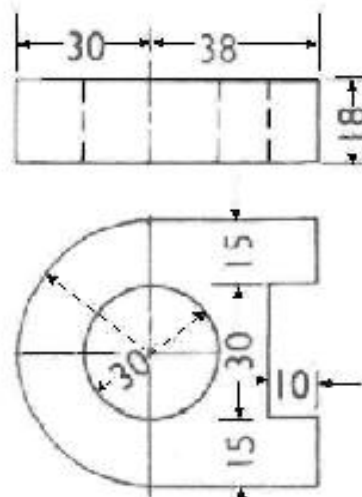

Figure 7

8. Draw the front view, top view and left side views of V- block as shown in figure.8. All dimensions are in mm [16]

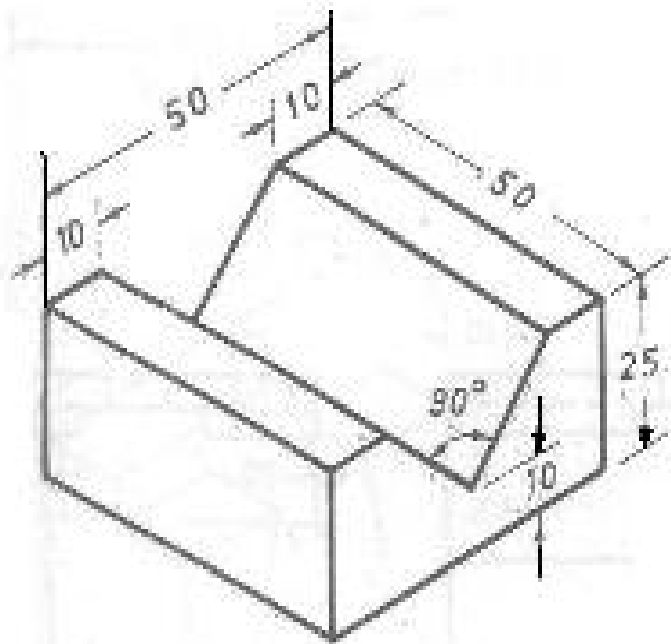

Figure 8

I B.Tech Regular Examinations, May/Jun 2008

ENGINEERING DRAWING

(Common to Electrical & Electronic Engineering, Electronics &
Instrumentation Engineering and Electronics & Computer Engineering)

Time: 3 hours

Max Marks: 80

Answer any FIVE Questions
All Questions carry equal marks

1. (a) Inscribe an ellipse in a parallelogram having sides 150mm and 100mm long and an inclined angle of 120^0 .
(b) Draw a rectangle having its sides 125mm and 75mm long. Inscribe two parabolas in it with their axis bisecting each other. [8+8]
2. Draw a hypo cycloid of a circle of 30mm diameter which rolls inside another circle of 160mm diameter, for one revolution counter clock wise. Draw a tangent and a normal to it at a point 60mm from the center of the directing circle. [16]
3. Draw the projections of the following points on the same ground line, keeping the Projectors 20mm apart.
 - (a) Point C, in the V.P. and 40mm above the H.P.
 - (b) Point D, 25mm below the H.P. and 25mm behind the V.P.
 - (c) Point E, 15mm above the H.P. and 50mm behind the V.P.
 - (d) Point F, 40mm below the H.P. and 25mm in front of the V.P. [4×4]
4. A line AB of 70mm long, has its end A at 10mm above H.P. and 15mm in front of V.P. Its front view and top view measure 50mm and 60mm respectively. Draw the projections of the line and determine its inclinations with H.P. and V.P. [16]
5. Draw the projections of a circle of 60 mm diameter, resting on V.P. on a point on the circumference. The plane is inclined at 45^0 to V.P. and perpendicular to H.P. The centre of the plane is 40mm above H.P. [16]
6. (a) Draw the projections of
 - i. a cylinder, base 40 mm diameter and axis 50 mm long, and
 - ii. a cone, base 40mm diameter and axis 50mm long, resting on the H.P. on their respective bases.(b) A hexagonal prism has one of its rectangular faces parallel to the H.P. Its axis is perpendicular to the V.P. and 3.5 cm above the ground. Draw its projections when the nearer end is 2 cm in front of the V.P. Side of base 2.5cm long, axis 5 cm long.
(c) A cube of 40mm side rests with one of its square faces on the H.P. such that one of its vertical faces is perpendicular to V.P. Draw its projections. The nearest edge parallel to V.P. is 5mm in front of it. [8+4+4]

7. Draw the isometric view of the ribbed angle plate, Shown in figure 7 All dimensions are in mm. [16]

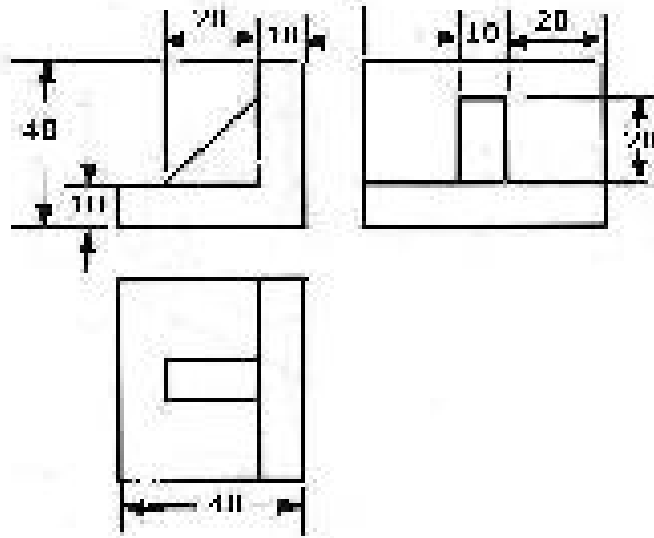

Figure 7

8. Draw the elevation, plan, left and right side views of the part shown in the figure 8. (All dimensions are in mm). [16]

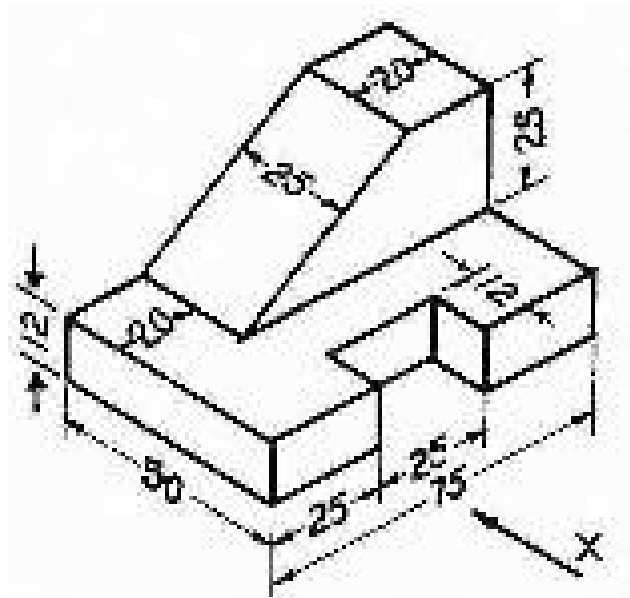

Figure 8
